



DEPARTMENT OF REGULATORY AND ECONOMIC RESOURCES (RER)  
 BOARD AND CODE ADMINISTRATION DIVISION  
**NOTICE OF ACCEPTANCE (NOA)**

MIAMI-DADE COUNTY  
 PRODUCT CONTROL SECTION  
 11805 SW 26 Street, Room 208  
 Miami, Florida 33175-2474  
 T (786) 315-2590 F (786) 315-2599  
[www.miamidade.gov/economy](http://www.miamidade.gov/economy)

**BASF Corporation (FL)**  
 3550 St. Johns Bluff Rd. South  
 Jacksonville, FL 32224

**SCOPE:**

This NOA is being issued under the applicable rules and regulations governing the use of construction materials. The documentation submitted has been reviewed and accepted by Miami-Dade County RER-Product Control Section to be used in Miami Dade County and other areas where allowed by the Authority Having Jurisdiction (AHJ). This NOA shall not be valid after the expiration date stated below. The Miami-Dade County Product Control Section (In Miami Dade County) and/or the AHJ (in areas other than Miami Dade County) reserve the right to have this product or material tested for quality assurance purposes. If this product or material fails to perform in the accepted manner, the manufacturer will incur the expense of such testing and the AHJ may immediately revoke, modify, or suspend the use of such product or material within their jurisdiction. RER reserves the right to revoke this acceptance, if it is determined by Miami-Dade County Product Control Section that this product or material fails to meet the requirements of the applicable building code.

This product is approved as described herein, and has been designed to comply with the Florida Building Code, including the High Velocity Hurricane Zone.

**DESCRIPTION: Finestone Pebbletex-DCA EIF System with Finestop/RA over ½” Dens Glass Gold, GlasRoc or Securock Sheathing and 18/20ga Steel Frame – S.M.I.**

**APPROVAL DOCUMENT:** Drawing No. 003/004, titled “Finestone Assembly Detail for Pebbletex-DCA Wall System with Finestop/RA over Dens Glass Gold, GlasRoc or Securock Sheathing and 18/20ga Steel Frame”, both sets with 4 sheets each, dated 06/16/2009 and 12/10/2013, prepared by BASF Corporation, signed and sealed by William O. Bishop, P.E., bearing the Miami-Dade County Product Control renewal stamp with the Notice of Acceptance number and expiration date by the Miami-Dade County Product Control Section.

**MISSILE IMPACT RATING: Small Missile Impact Resistant**

**LABELING:** Each unit shall bear a permanent label with the manufacturer's name or logo, city, state and following statement: "Miami-Dade County Product Control Approved", unless otherwise noted herein. Each container (bucket or drum) needs to be labeled. Unit is further defined as each roll of reinforcing mesh.

**RENEWAL** of this NOA shall be considered after a renewal application has been filed and there has been no change in the applicable building code negatively affecting the performance of this product.

**TERMINATION** of this NOA will occur after the expiration date or if there has been a revision or change in the materials, use, and/or manufacture of the product or process. Misuse of this NOA as an endorsement of any product, for sales, advertising or any other purposes shall automatically terminate this NOA. Failure to comply with any section of this NOA shall be cause for termination and removal of NOA.

**ADVERTISEMENT:** The NOA number preceded by the words Miami-Dade County, Florida, and followed by the expiration date may be displayed in advertising literature. If any portion of the NOA is displayed, then it shall be done in its entirety.

**INSPECTION:** A copy of this entire NOA shall be provided to the user by the manufacturer or its distributors and shall be available for inspection at the job site at the request of the Building Official.

This NOA renews NOA # 09-0924.13 and consists of this page 1 and evidence pages E-1 and E-2, as well as approval document mentioned above.

The submitted documentation was reviewed by Carlos M. Utrera, P.E.



*[Handwritten Signature]*  
 03/14/2014

NOA No. 14-0121.14  
 Expiration Date: April 29, 2019  
 Approval Date: March 20, 2014  
 Page 1

NOTICE OF ACCEPTANCE: EVIDENCE SUBMITTED

**A. DRAWINGS**

1. Drawing No. **003/004**, titled "Finestone Assembly Detail for Pebbletex-DCA Wall System with Finestop/RA over Dens Glass Gold, GlasRoc or Securock Sheathing and 18/20ga Steel Frame", both sets with 4 sheets each, dated 06/16/2009 and 12/10/2013, prepared by BASF Corporation, signed and sealed by William O. Bishop, P.E.

**B. TESTS "Submitted under NOA # 09-0924.13"**

1. Test reports on 1) Uniform Static Air Pressure Test, Loading per FBC TAS 202-94  
2) Large Missile Impact Test per FBC, TAS 201-94  
3) Cyclic Wind Pressure Loading per FBC, TAS 203-94  
along with marked-up drawings and installation diagram of Finestone Pebbletex-DCA Wall (EIF) System on ½" USG Securock Glass-Mat, prepared by Hurricane Test Laboratory, LLC, Test Report No. **0469-0409-09**, dated 07/21/2009, signed and sealed by Vinu J. Abraham, P.E.

2. Test reports on 1) Uniform Static Air Pressure Test, Loading per FBC TAS 202-94  
2) Large Missile Impact Test per FBC, TAS 201-94  
3) Cyclic Wind Pressure Loading per FBC, TAS 203-94  
along with marked-up drawings and installation diagram of Finestone Pebbletex-DCA Wall (EIF) System on ½" USG Securock Glass-Mat, prepared by Hurricane Test Laboratory, LLC, Test Report No. **0469-0410-09**, dated 07/21/2009, signed and sealed by Vinu J. Abraham, P.E.

**"Submitted under NOA # 09-0303.15"**

3. Test reports on 1) Air Infiltration Test, per FBC, TAS 202-94  
2) Uniform Static Air Pressure Test, Loading per FBC TAS 202-94  
3) Water Resistance Test, per FBC, TAS 202-94  
4) Small Missile Impact Test per FBC, TAS 201-94  
5) Cyclic Wind Pressure Loading per FBC, TAS 203-94  
along with marked-up drawings and installation diagram of Finestone Pebbletex-DCA Wall System (EIFS) with 4" wide sheathing fabric embedded in Finestop-RA, prepared by Hurricane Test Laboratory, LLC, Test Report No. **0469-0801-07**, dated 09/12/2008, signed and sealed by Vinu J. Abraham, P.E.

  
03/14/2014

---

Carlos M. Utrera, P.E.  
Product Control Examiner  
NOA No. 14-0121.14  
Expiration Date: April 29, 2019  
Approval Date: March 20, 2014

NOTICE OF ACCEPTANCE: EVIDENCE SUBMITTED

**B. TESTS (Continued) "Submitted under NOA # 09-0303.15"**

4. Test reports on 1) Air Infiltration Test, per FBC, TAS 202-94  
2) Uniform Static Air Pressure Test, Loading per FBC TAS 202-94  
3) Water Resistance Test, per FBC, TAS 202-94  
4) Small Missile Impact Test per FBC, TAS 201-94  
5) Cyclic Wind Pressure Loading per FBC, TAS 203-94

along with marked-up drawings and installation diagram of Finestone Pebbletex-DCA Wall System (EIFS) with 4" wide self-adhering mesh tape embedded in Finestop, prepared by Hurricane Test Laboratory, LLC, Test Report No. **0469-0802-07**, dated 09/12/2008, signed and sealed by Vinu J. Abraham, P.E.

**C. CALCULATIONS**

1. None.

**D. QUALITY ASSURANCE**

1. Miami-Dade Department of Regulatory and Economic Resources (RER)

**E. MATERIAL CERTIFICATIONS**

1. None.

**F. STATEMENTS**

1. Drawing statement of code conformance to 2010 FBC prepared by BASF Corporation, dated 12/10/2013, signed and sealed by William O. Bishop, P.E.

*"Submitted under NOA # 09-0924.13"*

2. Laboratory compliance letters for Test Reports No. **0469-0409-09** and **0469-0410-09**, issued by Hurricane Test Laboratory, LLC, both dated 07/21/2009, signed and sealed by Vinu J. Abraham, P.E.

*"Submitted under NOA # 09-0303.15"*

3. Laboratory compliance letters for Test Reports No. **0469-0801-07** and **0469-0802-07**, issued by Hurricane Test Laboratory, LLC, both dated 09/12/2008, signed and sealed by Vinu J. Abraham, P.E.

  
03/14/2014

---

Carlos M. Utrera, P.E.  
Product Control Examiner  
NOA No. 14-0121.14  
Expiration Date: April 29, 2019  
Approval Date: March 20, 2014

# FINESTONE

DATE: 12/10/13 Page 1 of 4

Assembly Detail for  
Pebbletex-DCA Wall System with  
Finestop over Dens Glass Gold,  
GlasRoc or Securock Sheathing  
and 18ga Steel Frame (Small  
Missile)

DWG No. 003

REVISIONS	DATES
Added Securock	6/16/09
FBC Version	12/10/13

FLORIDA P.E.: William O. Bishop, P.E.  
REGISTRATION NO.: 63305

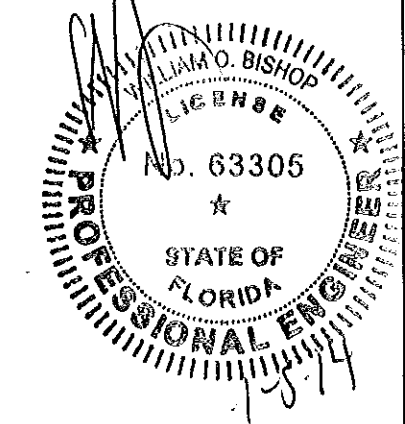

FOR OFFICE USE

PRODUCT RENEWED  
as complying with the Florida  
Building Code  
Acceptance No. 14-0121-14  
Expiration Date 04/29/2019  
By *[Signature]*  
Miami Dade Product Control

BASF Corporation  
3550 St Johns Bluff Rd South  
Jacksonville, FL 32224  
800-221-9255

## APPLICATION NOTES

- 1) SELF-ADHERING MESH TAPE IS APPLIED OVER SHEATHING JOINTS.
- 2) FINESTOP IS MIXED AT THE TIME OF USE WITH PORTLAND CEMENT (1 TO 1 BY WEIGHT) AND WATER WITH PADDLE AND DRILL TO A HOMOGENEOUS CONSISTENCY.
- 3) APPLY FINESTOP TO SHEATHING SURFACE UNIFORMLY AT 3/32" THICKNESS.
- 4) FINESTONE BASE COAT IS MIXED AT THE TIME OF USE WITH PORTLAND CEMENT (1 TO 1 BY WEIGHT) AND WATER WITH PADDLE AND DRILL TO A HOMOGENEOUS CONSISTENCY.
- 5) FINESTONE BASE COAT IS APPLIED TO THE BACK OF THE EPS INSULATION BOARD USING A 1/2" X 1/2" U NOTCHED TROWEL HAVING 2" FLAT SEGMENTS BETWEEN NOTCHES.
- 6) MIAMI-DADE COUNTY APPROVED EPS INSULATION HAS A DENSITY OF 1 PCF AND IT SHALL BE APPLIED HORIZONTALLY IN A RUNNING BOND PATTERN STAGGERING VERTICAL JOINTS AND CORNERS.
- 7) AFTER BASE COAT IS DRIED AND INSULATION BOARD IS RASPED TO A SMOOTH SURFACE, A LAYER OF FINESTONE BASE COAT IS APPLIED TO THE EXPOSED SURFACE. STANDARD REINFORCING MESH IS EMBEDDED IN THE WET BASE COAT BY TROWELING FROM THE CENTER OUT. ALL EDGES ARE LAPPED 2 1/2 INCHES.
- 8) FINESTONE FINISH IS AN ACRYLIC BASED TEXTURED EXTERIOR COATING READY MIXED FROM THE FACTORY. IT IS APPLIED WITH A STAINLESS STEEL TROWEL AND FLOATED TO A DESIRED TEXTURE.

## GENERAL NOTES

- 1) THIS SYSTEM HAS BEEN DESIGNED IN ACCORDANCE WITH THE FLORIDA BUILDING CODE 2010 EDITION AND ITS LATEST SUPPLEMENTS.
- 2) THIS SYSTEM HAS BEEN TESTED IN ACCORDANCE WITH MIAMI-DADE COUNTY PROTOCOL TAS-201, TAS-202 & TAS-203 FOR SMALL MISSILE IMPACT, STRUCTURAL AND CYCLIC TESTING.
- 3) THIS SYSTEM SHALL BE APPLIED BY A LICENSED PLASTERING CONTRACTOR FOLLOWING THIS NOTICE OF ACCEPTANCE, THE RECOMMENDATIONS OF FINESTONE AND THE APPLICABLE SECTION OF THE FLORIDA BUILDING CODE.
- 4) THE ENGINEER AND/OR ARCHITECT OF RECORD FOR EACH PROJECT USING THIS SYSTEM SHALL SIZE ALL STUD FRAMING TO ENSURE CONFORMANCE WITH STUD DEFLECTION AND STRESS LIMITATIONS AS REQUIRED BY GOVERNING CODE AND THIS DOCUMENT.
- 5) ALL STUDS USED WITH THIS SYSTEM SHALL BE COMPLETELY SHEATHED AT THE INTERIOR FLANGE OR BRIDGED AT MAXIMUM EVERY 5 FT. OF STUD LENGTH OR AS SPECIFIED BY THE MANUFACTURER.
- 6) ALL STEEL STUDS SHALL BE STRUCTURAL WITH 1 5/8" MIN FLANGE WIDTH AND HAVE A MINIMUM YIELD STRENGTH OF 33000 PSI
- 7) DETAILS ON SHEET 3 & 4 OF 4 ARE TYPICAL AND SHOW INTENT TO PREVENT WATER INFILTRATION INTO AND BEHIND THE SYSTEM. ALTERNATE DETAILS AND SPECIFIC CONDITIONS NOT COVERED BY THE TYPICAL DETAILS ARE THE RESPONSIBILITY OF THE LICENSED DESIGN PROFESSIONAL IN CONSULTATION WITH FINESTONE.

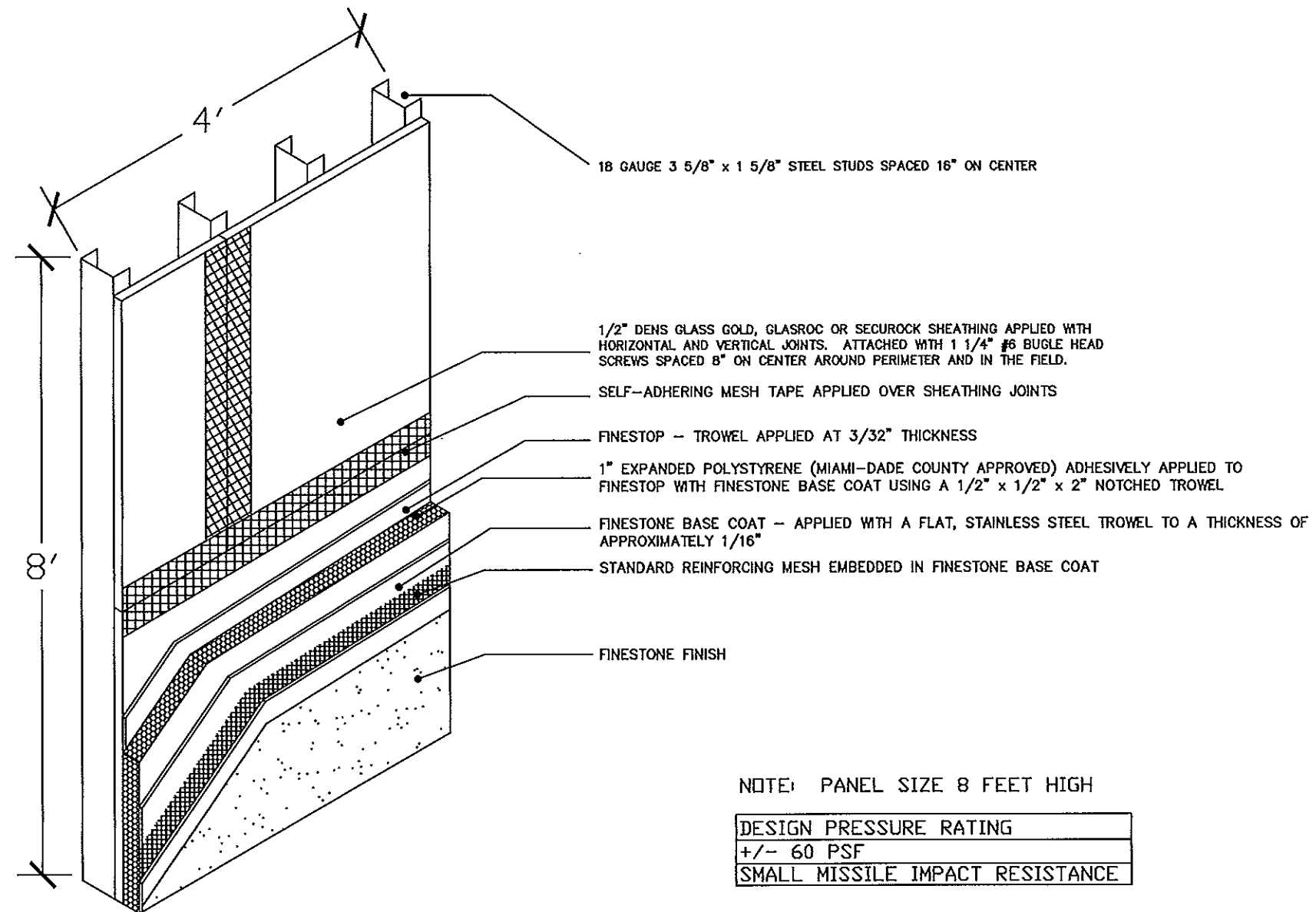

# FINESTONE

DATE: 12/10/13 Page 2 of 4

Assembly Detail for  
Pebbletex-DCA Wall System with  
Finestop over Dens Glass Gold,  
GlasRoc or Securock Sheathing  
and 20ga Steel Frame (Small  
Missile)

DWG No. 003

REVISIONS	DATES
Added Securock	6/16/09
FBC Version	12/10/13

FLORIDA P.E.: William O. Bishop, P.E.  
REGISTRATION NO.: 63305

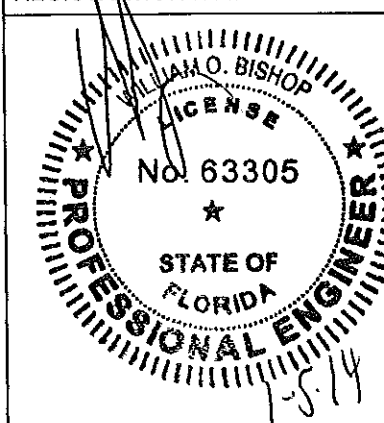

FOR OFFICE USE

PRODUCT RENEWED  
as complying with the Florida  
Building Code  
Acceptance No. 14-0121-K  
Expiration Date 04/29/2019  
By *[Signature]*  
Miami Dade Product Control

BASF Corporation  
3550 St Johns Bluff Rd South  
Jacksonville, FL 32224  
800-221-9255

## APPLICATION NOTES

- 1) SELF-ADHERING MESH TAPE IS APPLIED OVER SHEATHING JOINTS.
- 2) FINESTOP IS MIXED AT THE TIME OF USE WITH PORTLAND CEMENT (1 TO 1 BY WEIGHT) AND WATER WITH PADDLE AND DRILL TO A HOMOGENEOUS CONSISTENCY.
- 3) APPLY FINESTOP TO SHEATHING SURFACE UNIFORMLY AT 3/32" THICKNESS.
- 4) FINESTONE BASE COAT IS MIXED AT THE TIME OF USE WITH PORTLAND CEMENT (1 TO 1 BY WEIGHT) AND WATER WITH PADDLE AND DRILL TO A HOMOGENEOUS CONSISTENCY.
- 5) FINESTONE BASE COAT IS APPLIED TO THE BACK OF THE EPS INSULATION BOARD USING A 1/2" X 1/2" U NOTCHED TROWEL HAVING 2" FLAT SEGMENTS BETWEEN NOTCHES.
- 6) MIAMI-DADE COUNTY APPROVED EPS INSULATION HAS A DENSITY OF 1 PCF AND IT SHALL BE APPLIED HORIZONTALLY IN A RUNNING BOND PATTERN STAGGERING VERTICAL JOINTS AND CORNERS.
- 7) AFTER BASE COAT IS DRIED AND INSULATION BOARD IS RASPED TO A SMOOTH SURFACE, A LAYER OF FINESTONE BASE COAT IS APPLIED TO THE EXPOSED SURFACE. STANDARD REINFORCING MESH IS EMBEDDED IN THE WET BASE COAT BY TROWELING FROM THE CENTER OUT. ALL EDGES ARE LAPPED 2 1/2 INCHES.
- 8) FINESTONE FINISH IS AN ACRYLIC BASED TEXTURED EXTERIOR COATING READY MIXED FROM THE FACTORY. IT IS APPLIED WITH A STAINLESS STEEL TROWEL AND FLOATED TO A DESIRED TEXTURE.

## GENERAL NOTES

- 1) THIS SYSTEM HAS BEEN DESIGNED IN ACCORDANCE WITH THE FLORIDA BUILDING CODE 2010 EDITION AND ITS LATEST SUPPLEMENTS.
- 2) THIS SYSTEM HAS BEEN TESTED IN ACCORDANCE WITH MIAMI-DADE COUNTY PROTOCOL TAS-201, TAS-202 & TAS-203 FOR SMALL MISSILE IMPACT, STRUCTURAL AND CYCLIC TESTING.
- 3) THIS SYSTEM SHALL BE APPLIED BY A LICENSED PLASTERING CONTRACTOR FOLLOWING THIS NOTICE OF ACCEPTANCE, THE RECOMMENDATIONS OF FINESTONE AND THE APPLICABLE SECTION OF THE FLORIDA BUILDING CODE.
- 4) THE ENGINEER AND/OR ARCHITECT OF RECORD FOR EACH PROJECT USING THIS SYSTEM SHALL SIZE ALL STUD FRAMING TO ENSURE CONFORMANCE WITH STUD DEFLECTION AND STRESS LIMITATIONS AS REQUIRED BY GOVERNING CODE AND THIS DOCUMENT.
- 5) ALL STUDS USED WITH THIS SYSTEM SHALL BE COMPLETELY SHEATHED AT THE INTERIOR FLANGE OR BRIDGED AT MAXIMUM EVERY 5 FT. OF STUD LENGTH OR AS SPECIFIED BY THE MANUFACTURER.
- 6) ALL STEEL STUDS SHALL BE STRUCTURAL WITH 1 5/8" MIN FLANGE WIDTH AND HAVE A MINIMUM YIELD STRENGTH OF 33000 PSI
- 7) DETAILS ON SHEET 3 & 4 OF 4 ARE TYPICAL AND SHOW INTENT TO PREVENT WATER INFILTRATION INTO AND BEHIND THE SYSTEM. ALTERNATE DETAILS AND SPECIFIC CONDITIONS NOT COVERED BY THE TYPICAL DETAILS ARE THE RESPONSIBILITY OF THE LICENSED DESIGN PROFESSIONAL IN CONSULTATION WITH FINESTONE.

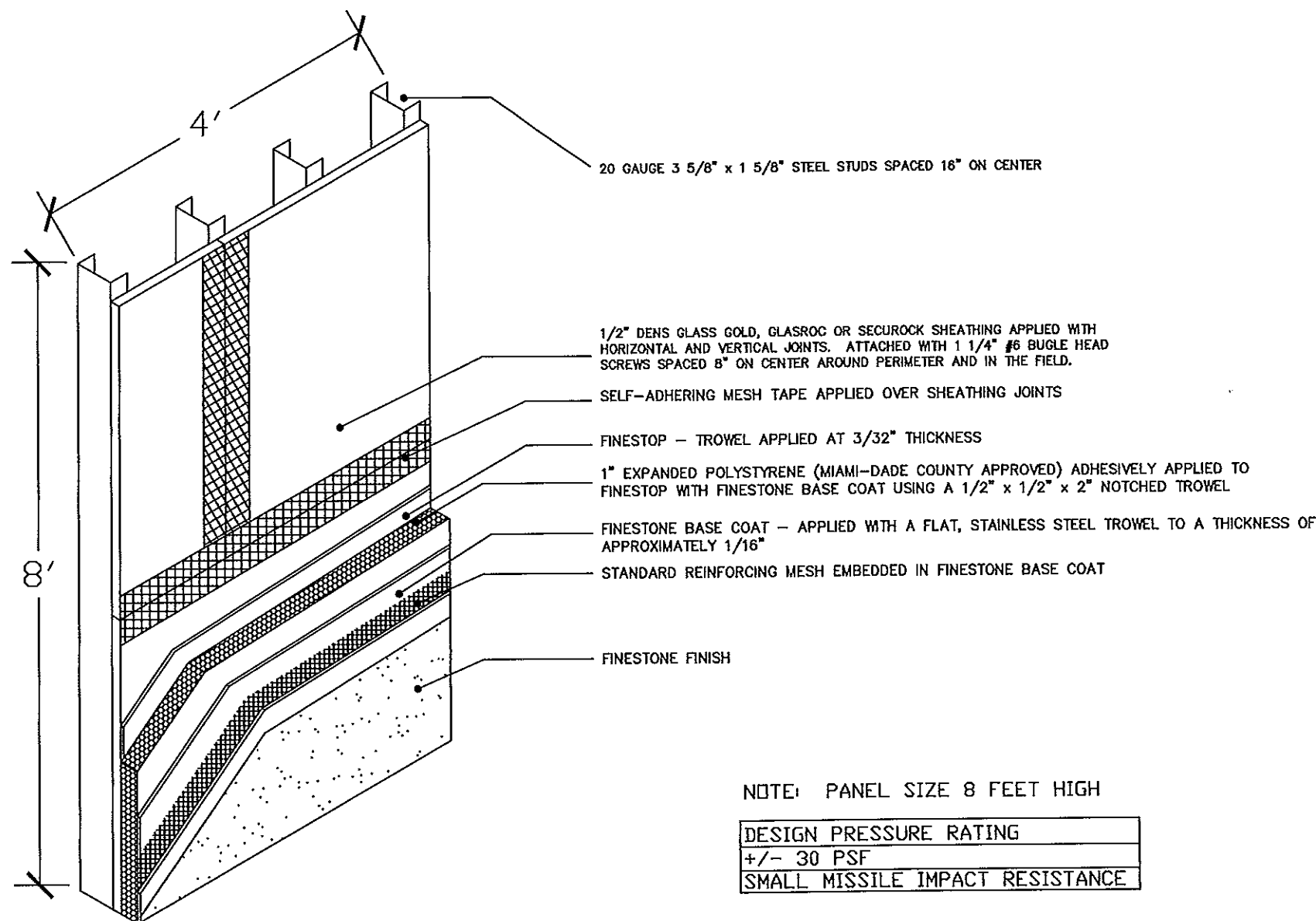

# FINESTONE

DATE: 12/10/13

Page 3 of 4

Details for Pebbletex-DCA Wall System with Finestop over Dens Glass Gold, GlasRoc or Securock Sheathing and 18ga or 20ga Steel Frame (Small Missile)

DWG No. 003

REVISIONS DATES

Added Securock 6/16/09

FLORIDA P.E.: William O. Bishop, P.E.  
REGISTRATION NO.: 63305

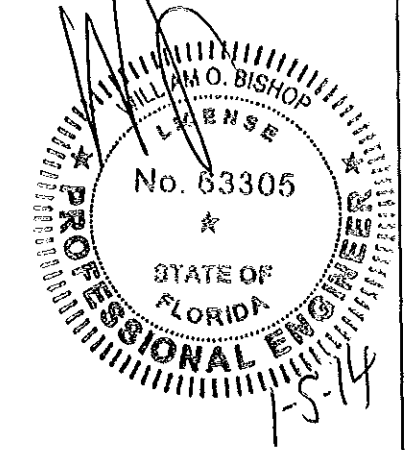

FOR OFFICE USE

PRODUCT RENEWED  
as complying with the Florida  
Building Code  
Acceptance No 14-012114  
Expiration Date 04/29/2019

By *[Signature]*  
Miami Dade Product Control

BASF Corporation  
3550 St Johns Bluff Rd South  
Jacksonville, FL 32224  
800-221-9255

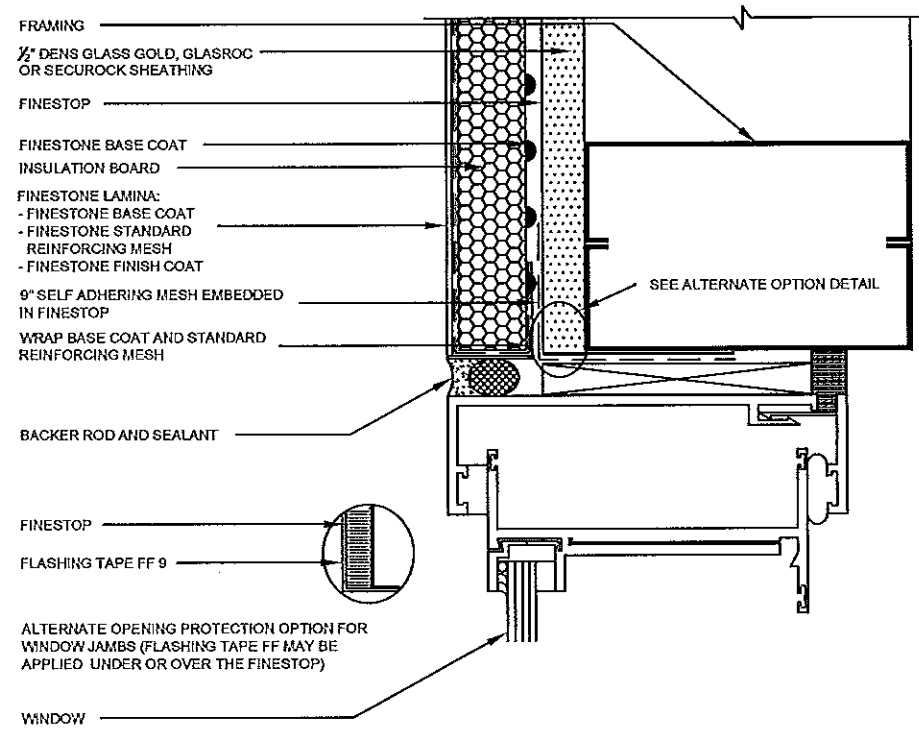

WINDOW JAMB DETAIL (FLUSH)

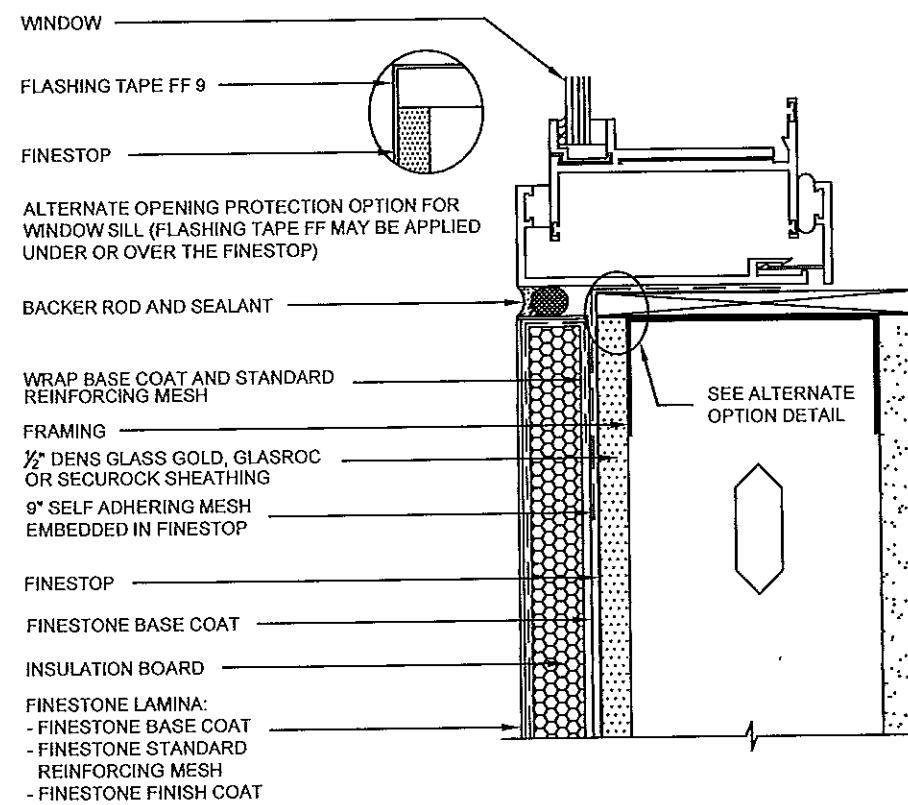

WINDOW SILL DETAIL (FLUSH)

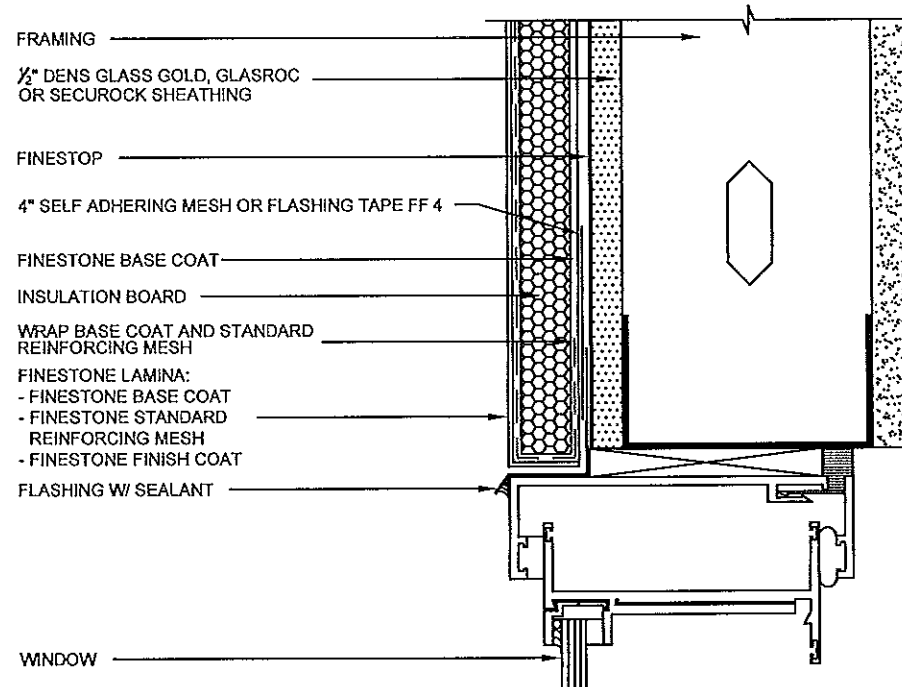

WINDOW HEAD (FLUSH)

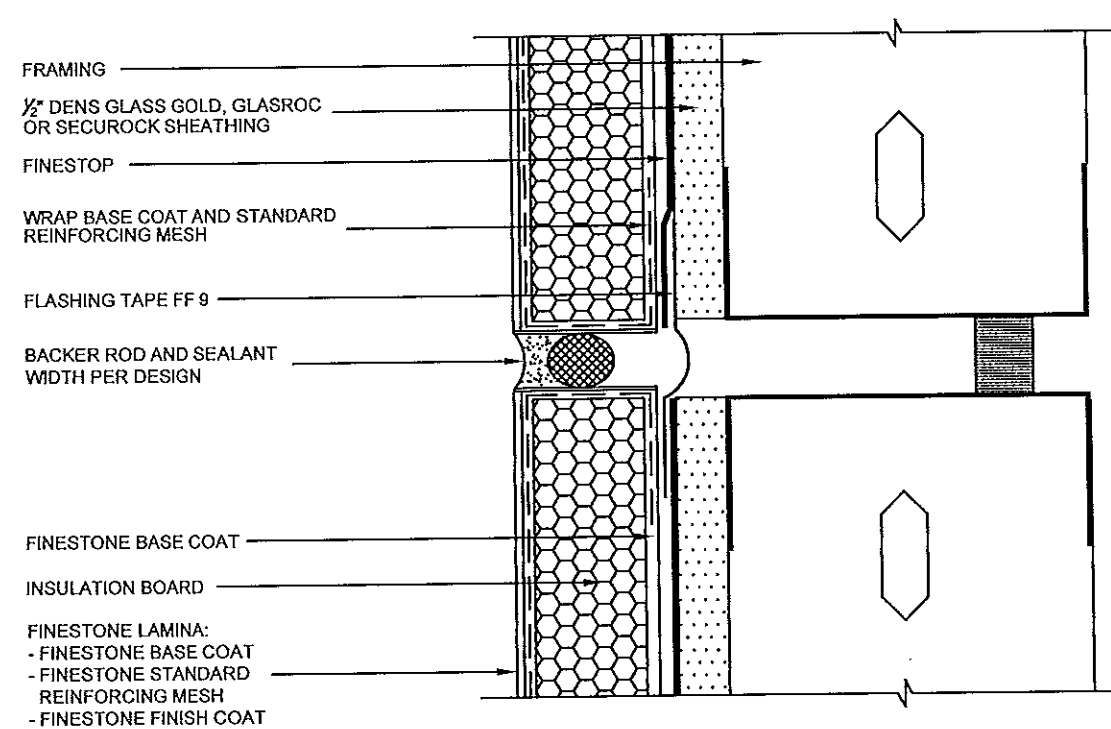

EXPANSION JOINT DETAIL

Details for Pebbletex-DCA Wall System with Finestop over Dens Glass Gold, GlasRoc or Securock Sheathing and 18ga or 20ga Steel Frame (Small Missile)

DWG No. 003

REVISIONS	DATES
Added Securock	6/16/09

FLORIDA P.E.: William O. Bishop, P.E.  
REGISTRATION NO.: 63305

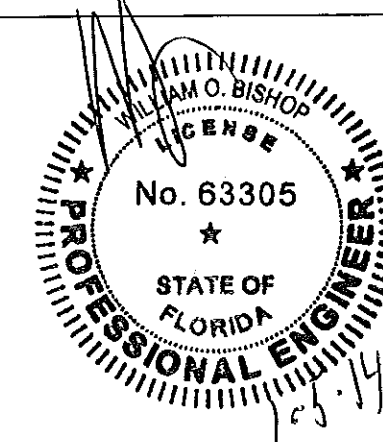

FOR OFFICE USE

**PRODUCT RENEWED**  
as complying with the Florida  
Building Code  
Acceptance No 14-0121-14  
Expiration Date 04/29/2019

By *[Signature]*  
Miami Dade Product Control

BASF Corporation  
3550 St Johns Bluff Rd South  
Jacksonville, FL 32224  
800-221-9255

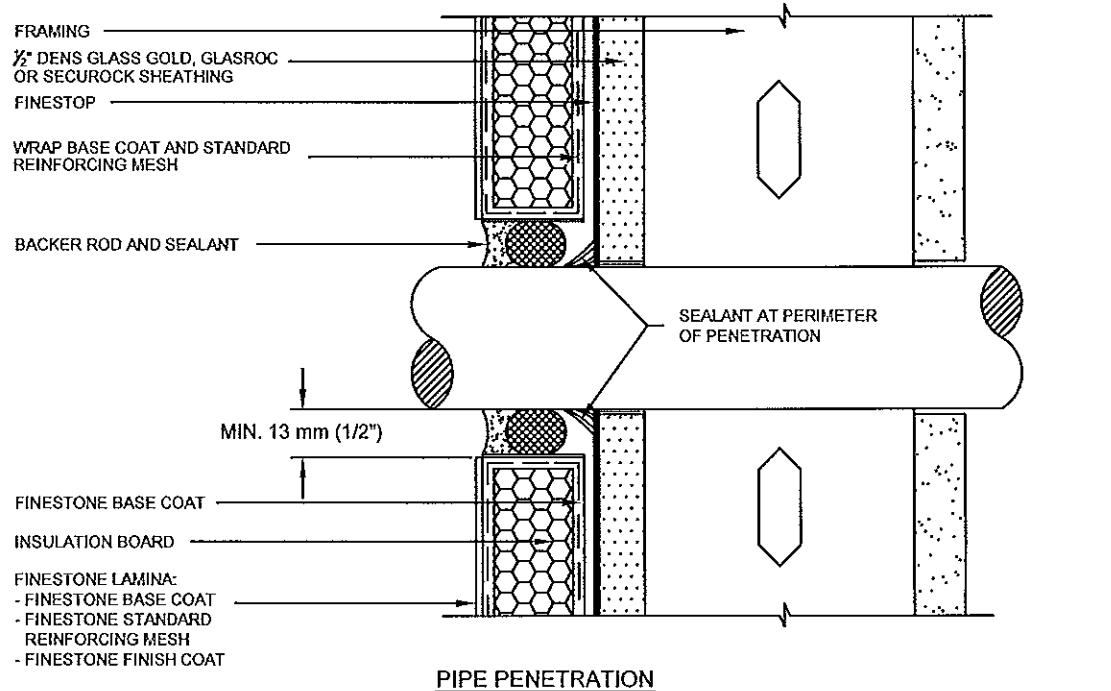

**PIPE PENETRATION**

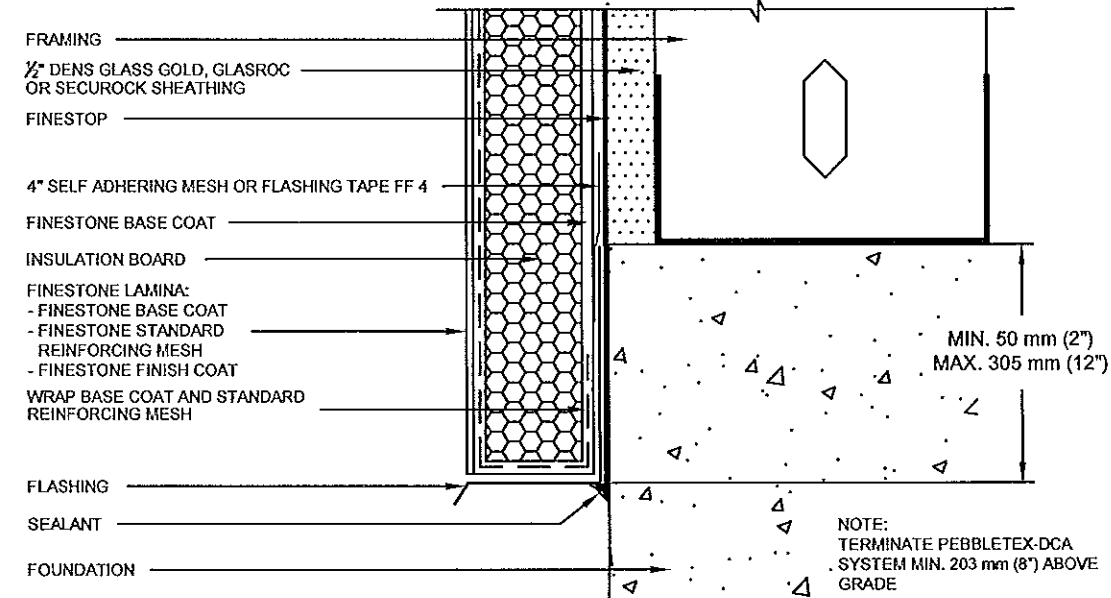

**TERMINATION AT FOUNDATION**

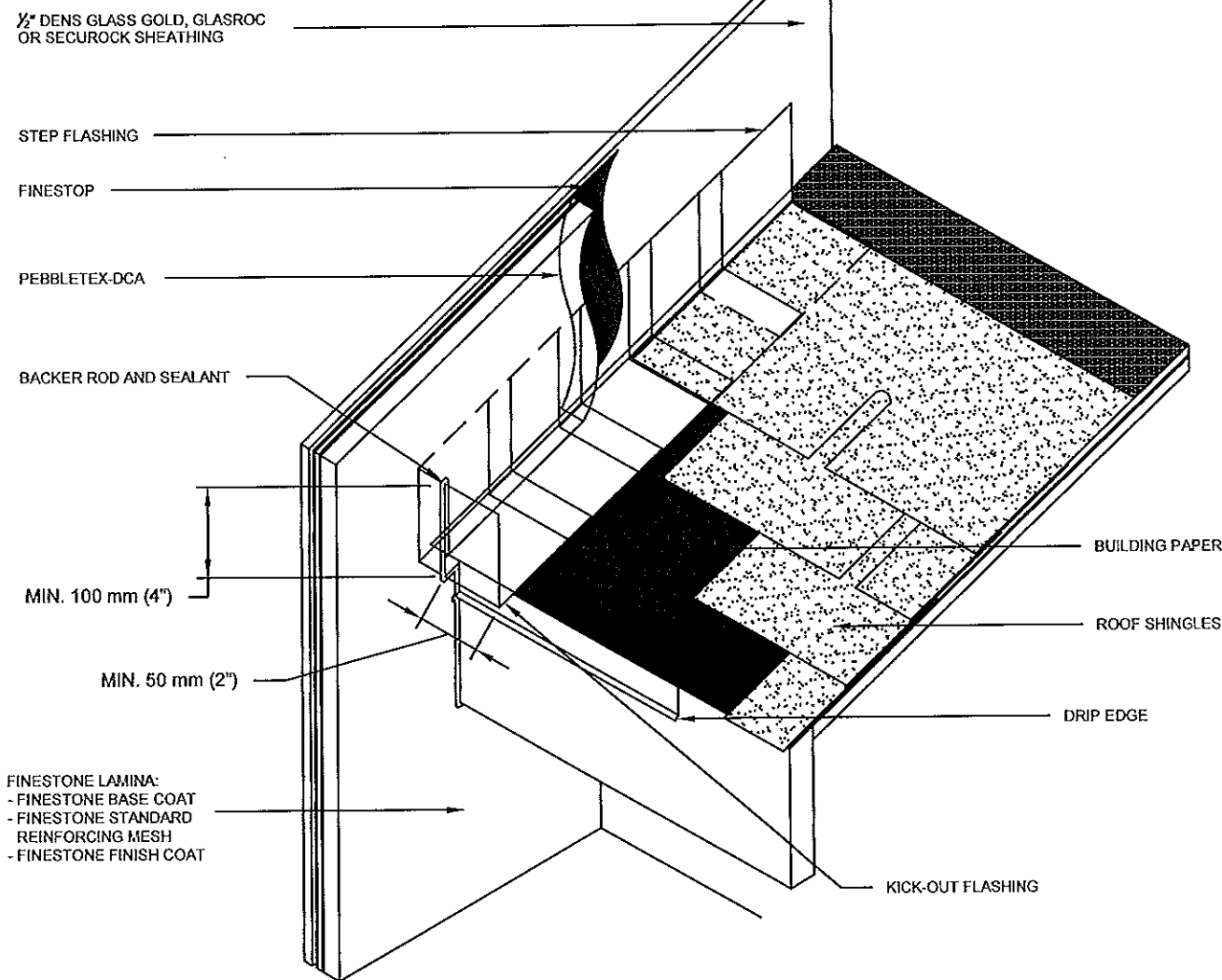

NOTE:  
- KICK-OUT FLASHING MUST BE ANGLED 100° MIN. TO ALLOW FOR PROPER DRAINAGE.  
- KICK-OUT FLASHING SEAMS MUST BE SOLDERED OR SEALED WITH APPROPRIATE SEALANT.  
- TERMINATE PEBBLETEX-DCA MIN. 50 mm (2") ABOVE ROOF.  
- ROOFING DETAIL SHALL COMPLY WITH CHAPTER 15 OF THE F.B.C.

**KICKOUT FLASHING DETAIL**

# FINESTONE

DATE: 12/10/13 Page 1 of 4

Assembly Detail for  
Pebbletex-DCA Wall System with  
Finestop-RA over Dens Glass  
Gold, GlasRoc or Securock  
Sheathing and 18ga Steel Frame  
(Small Missile)

DWG No. 004

REVISIONS	DATES
-----------	-------

Added Securock	6/16/09
FBC Version	12/10/13

FLORIDA P.E.: William O. Bishop, P.E.  
REGISTRATION NO.: 63305

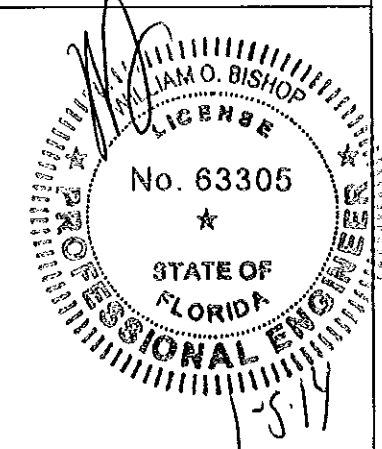

FOR OFFICE USE

PRODUCT RENEWED  
as complying with the Florida  
Building Code  
Acceptance No. 14-012114  
Expiration Date 04/29/2019  
By *[Signature]*  
Miami Dade Product Control

BASF Corporation  
3550 St Johns Bluff Rd South  
Jacksonville, FL 32224  
800-221-9255

## APPLICATION NOTES

- 1) SHEATHING FABRIC IS EMBEDDED IN FINESTOP-RA AT SHEATHING JOINTS. SHEATHING FASTENERS ARE SPOTTED WITH FINESTOP-RA.
- 2) APPLY FINESTOP-RA TO SHEATHING SURFACE UNIFORMLY AT 10 MILS WET.
- 3) FINESTONE BASE COAT IS MIXED AT THE TIME OF USE WITH PORTLAND CEMENT (1 TO 1 BY WEIGHT) AND WATER WITH PADDLE AND DRILL TO A HOMOGENEOUS CONSISTENCY.
- 4) FINESTONE BASE COAT IS APPLIED TO THE BACK OF THE EPS INSULATION BOARD USING A 1/2" X 1/2" U NOTCHED TROWEL HAVING 2" FLAT SEGMENTS BETWEEN NOTCHES.
- 5) MIAMI-DADE COUNTY APPROVED EPS INSULATION HAS A DENSITY OF 1 PCF AND IT SHALL BE APPLIED HORIZONTALLY IN A RUNNING BOND PATTERN STAGGERING VERTICAL JOINTS AND CORNERS.
- 6) AFTER BASE COAT IS DRIED AND INSULATION BOARD IS RASPED TO A SMOOTH SURFACE, A LAYER OF FINESTONE BASE COAT IS APPLIED TO THE EXPOSED SURFACE. STANDARD REINFORCING MESH IS EMBEDDED IN THE WET BASE COAT BY TROWELING FROM THE CENTER OUT. ALL EDGES ARE LAPPED 2 1/2 INCHES.
- 7) FINESTONE FINISH IS AN ACRYLIC BASED TEXTURED EXTERIOR COATING READY MIXED FROM THE FACTORY. IT IS APPLIED WITH A STAINLESS STEEL TROWEL AND FLOATED TO A DESIRED TEXTURE.

## GENERAL NOTES

- 1) THIS SYSTEM HAS BEEN DESIGNED IN ACCORDANCE WITH THE FLORIDA BUILDING CODE 2010 EDITION AND ITS LATEST SUPPLEMENTS.
- 2) THIS SYSTEM HAS BEEN TESTED IN ACCORDANCE WITH MIAMI-DADE COUNTY PROTOCOL TAS-201, TAS-202 & TAS-203 FOR SMALL MISSILE IMPACT, STRUCTURAL AND CYCLIC TESTING.
- 3) THIS SYSTEM SHALL BE APPLIED BY A LICENSED PLASTERING CONTRACTOR FOLLOWING THIS NOTICE OF ACCEPTANCE, THE RECOMMENDATIONS OF FINESTONE AND THE APPLICABLE SECTION OF THE FLORIDA BUILDING CODE.
- 4) THE ENGINEER AND/OR ARCHITECT OF RECORD FOR EACH PROJECT USING THIS SYSTEM SHALL SIZE ALL STUD FRAMING TO ENSURE CONFORMANCE WITH STUD DEFLECTION AND STRESS LIMITATIONS AS REQUIRED BY GOVERNING CODE AND THIS DOCUMENT.
- 5) ALL STUDS USED WITH THIS SYSTEM SHALL BE COMPLETELY SHEATHED AT THE INTERIOR FLANGE OR BRIDGED AT MAXIMUM EVERY 5 FT. OF STUD LENGTH OR AS SPECIFIED BY THE MANUFACTURER.
- 6) ALL STEEL STUDS SHALL BE STRUCTURAL WITH 1 5/8" MIN FLANGE WIDTH AND HAVE A MINIMUM YIELD STRENGTH OF 33000 PSI
- 7) DETAILS ON SHEET 3 & 4 OF 4 ARE TYPICAL AND SHOW INTENT TO PREVENT WATER INFILTRATION INTO AND BEHIND THE SYSTEM. ALTERNATE DETAILS AND SPECIFIC CONDITIONS NOT COVERED BY THE TYPICAL DETAILS ARE THE RESPONSIBILITY OF THE LICENSED DESIGN PROFESSIONAL IN CONSULTATION WITH FINESTONE.

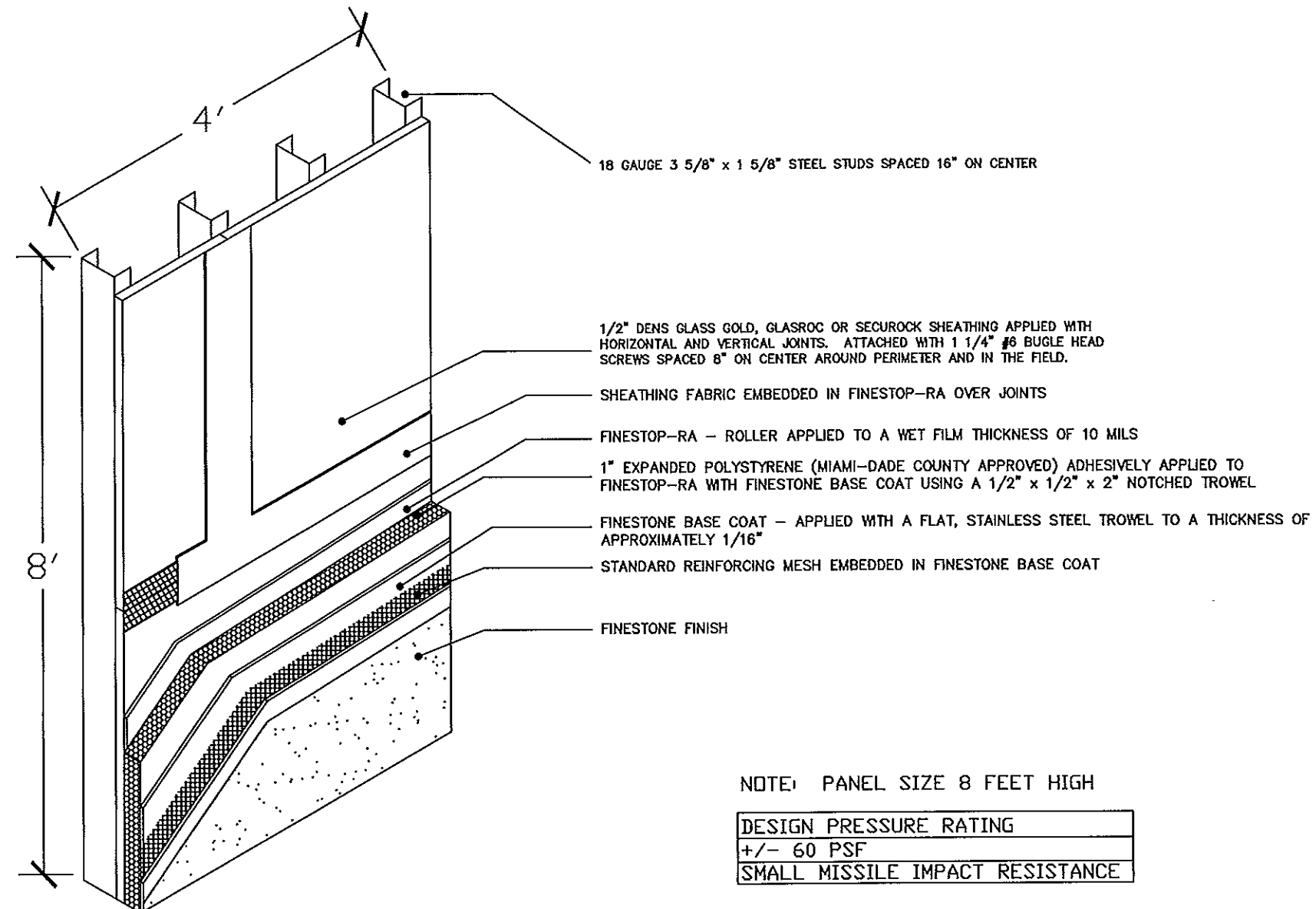



# FINESTONE

DATE: 12/10/13 Page 2 of 4

Assembly Detail for  
Pebbletex-DCA Wall System with  
Finestop-RA over Dens Glass  
Gold, GlasRoc or Securock  
Sheathing and 20ga Steel Frame  
(Small Missile)

DWG No. 004

REVISIONS	DATES
Added Securock	6/16/09
FBC Version	12/10/13

FLORIDA P.E.: William O. Bishop, P.E.  
REGISTRATION NO.: 63305

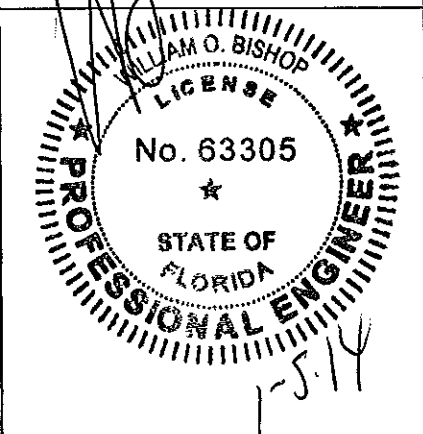

FOR OFFICE USE

PRODUCT RENEWED  
as complying with the Florida  
Building Code  
Acceptance No. 14-012/14  
Expiration Date 02/29/2019  
By *[Signature]*  
Miami Dade Product Control

BASF Corporation  
3550 St Johns Bluff Rd South  
Jacksonville, FL 32224  
800-221-9255

## APPLICATION NOTES

- 1) SHEATHING FABRIC IS EMBEDDED IN FINESTOP-RA AT SHEATHING JOINTS. SHEATHING FASTENERS ARE SPOTTED WITH FINESTOP-RA.
- 2) APPLY FINESTOP-RA TO SHEATHING SURFACE UNIFORMLY AT 10 MILS WET.
- 3) FINESTONE BASE COAT IS MIXED AT THE TIME OF USE WITH PORTLAND CEMENT (1 TO 1 BY WEIGHT) AND WATER WITH PADDLE AND DRILL TO A HOMOGENEOUS CONSISTENCY.
- 4) FINESTONE BASE COAT IS APPLIED TO THE BACK OF THE EPS INSULATION BOARD USING A 1/2" X 1/2" U NOTCHED TROWEL HAVING 2" FLAT SEGMENTS BETWEEN NOTCHES.
- 5) MIAMI-DADE COUNTY APPROVED EPS INSULATION HAS A DENSITY OF 1 PCF AND IT SHALL BE APPLIED HORIZONTALLY IN A RUNNING BOND PATTERN STAGGERING VERTICAL JOINTS AND CORNERS.
- 6) AFTER BASE COAT IS DRIED AND INSULATION BOARD IS RASPED TO A SMOOTH SURFACE, A LAYER OF FINESTONE BASE COAT IS APPLIED TO THE EXPOSED SURFACE. STANDARD REINFORCING MESH IS EMBEDDED IN THE WET BASE COAT BY TROWELING FROM THE CENTER OUT. ALL EDGES ARE LAPPED 2 1/2 INCHES.
- 7) FINESTONE FINISH IS AN ACRYLIC BASED TEXTURED EXTERIOR COATING READY MIXED FROM THE FACTORY. IT IS APPLIED WITH A STAINLESS STEEL TROWEL AND FLOATED TO A DESIRED TEXTURE.

## GENERAL NOTES

- 1) THIS SYSTEM HAS BEEN DESIGNED IN ACCORDANCE WITH THE FLORIDA BUILDING CODE 2010 EDITION AND ITS LATEST SUPPLEMENTS.
- 2) THIS SYSTEM HAS BEEN TESTED IN ACCORDANCE WITH MIAMI-DADE COUNTY PROTOCOL TAS-201, TAS-202 & TAS-203 FOR SMALL MISSILE IMPACT, STRUCTURAL AND CYCLIC TESTING.
- 3) THIS SYSTEM SHALL BE APPLIED BY A LICENSED PLASTERING CONTRACTOR FOLLOWING THIS NOTICE OF ACCEPTANCE, THE RECOMMENDATIONS OF FINESTONE AND THE APPLICABLE SECTION OF THE FLORIDA BUILDING CODE.
- 4) THE ENGINEER AND/OR ARCHITECT OF RECORD FOR EACH PROJECT USING THIS SYSTEM SHALL SIZE ALL STUD FRAMING TO ENSURE CONFORMANCE WITH STUD DEFLECTION AND STRESS LIMITATIONS AS REQUIRED BY GOVERNING CODE AND THIS DOCUMENT.
- 5) ALL STUDS USED WITH THIS SYSTEM SHALL BE COMPLETELY SHEATHED AT THE INTERIOR FLANGE OR BRIDGED AT MAXIMUM EVERY 5 FT. OF STUD LENGTH OR AS SPECIFIED BY THE MANUFACTURER.
- 6) ALL STEEL STUDS SHALL BE STRUCTURAL WITH 1 5/8" MIN FLANGE WIDTH AND HAVE A MINIMUM YIELD STRENGTH OF 33000 PSI
- 7) DETAILS ON SHEET 3 & 4 OF 4 ARE TYPICAL AND SHOW INTENT TO PREVENT WATER INFILTRATION INTO AND BEHIND THE SYSTEM. ALTERNATE DETAILS AND SPECIFIC CONDITIONS NOT COVERED BY THE TYPICAL DETAILS ARE THE RESPONSIBILITY OF THE LICENSED DESIGN PROFESSIONAL IN CONSULTATION WITH FINESTONE.

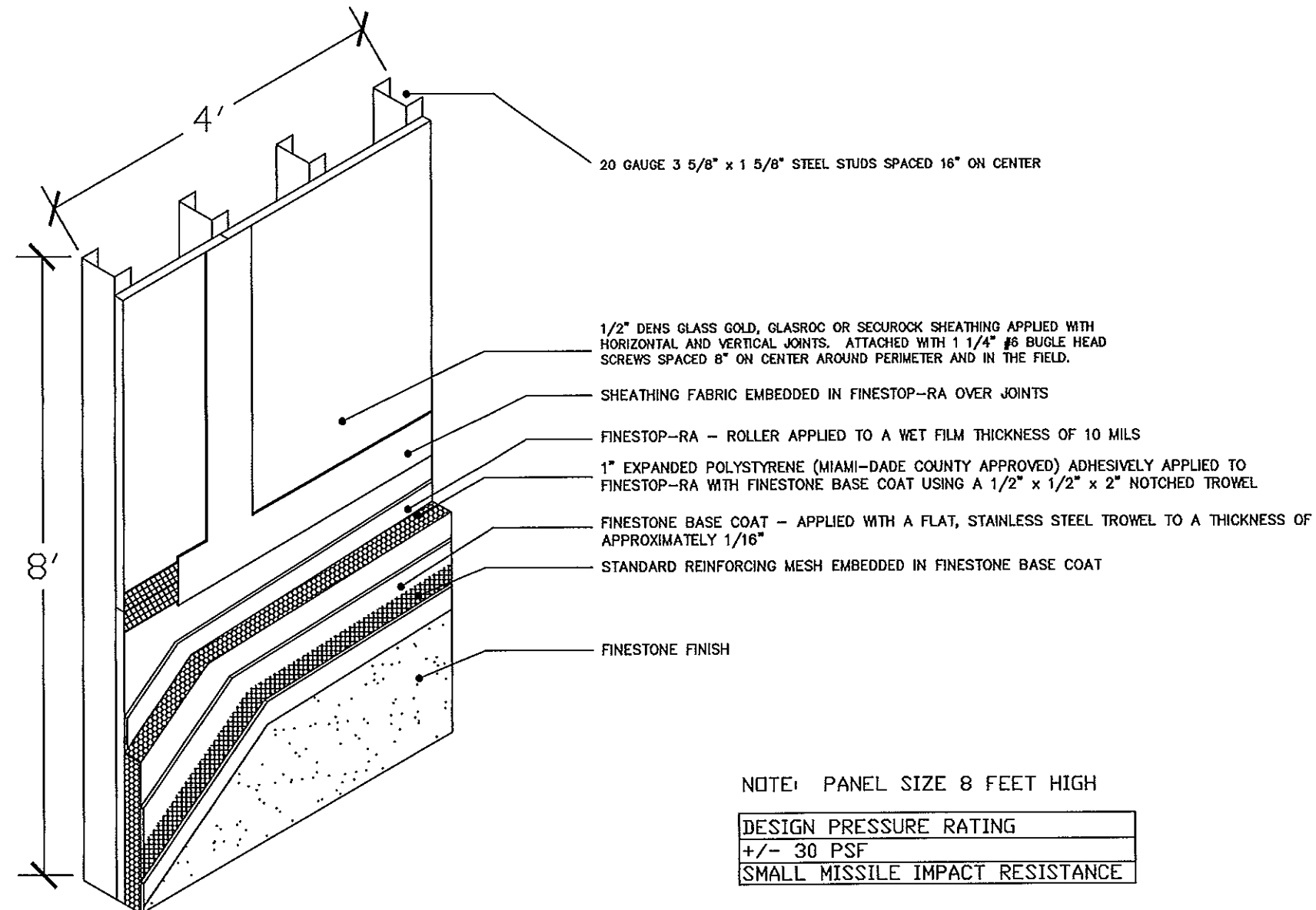

NOTE: PANEL SIZE 8 FEET HIGH

DESIGN PRESSURE RATING
+/- 30 PSF
SMALL MISSILE IMPACT RESISTANCE

# FINESTONE

DATE: 12/10/13 Page 3 of 4

Details for Pebbietex-DCA Wall System with Finestop-RA over Dens Glass Gold, GlasRoc or Securock Sheathing and 18ga or 20ga Steel Frame (Small Missile)

DWG No. 004

REVISIONS DATES

Added Securock 6/16/09

FLORIDA P.E.: William O. Bishop, P.E.  
REGISTRATION NO.: 63305

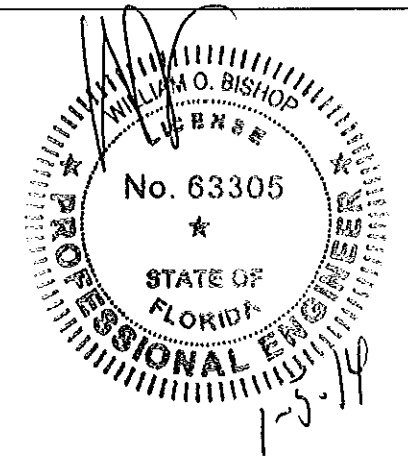

FOR OFFICE USE

PRODUCT RENEWED  
as complying with the Florida  
Building Code  
Acceptance No 14-0121-19  
Expiration Date 04/29/2019

By *[Signature]*  
Miami Dade Product Control

BASF Corporation  
3550 St Johns Bluff Rd South  
Jacksonville, FL 32224  
800-221-9255

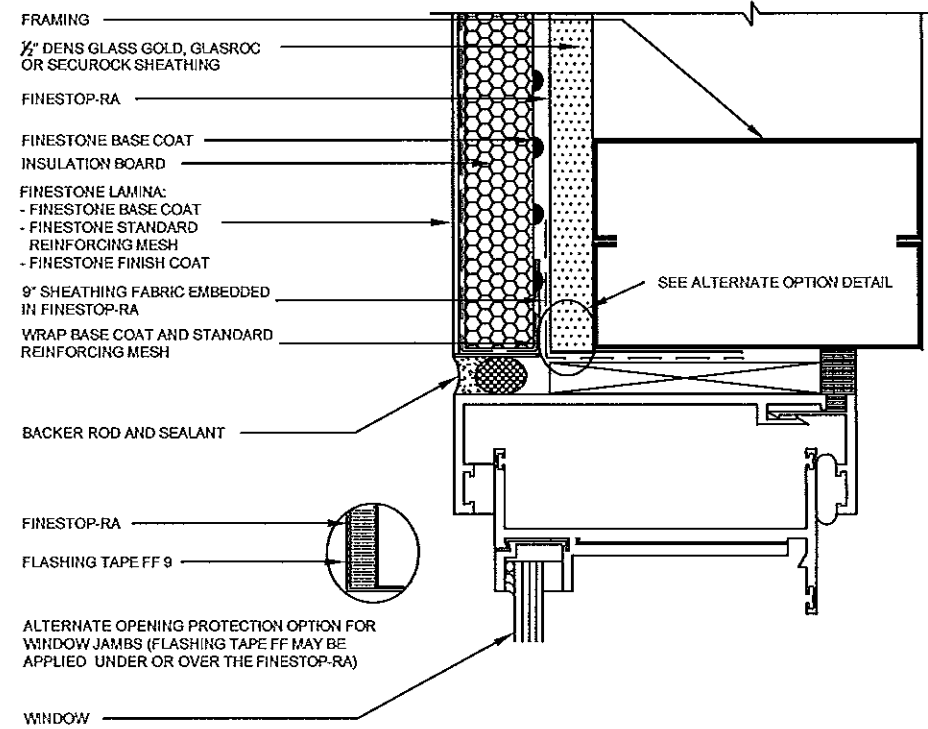

WINDOW JAMB DETAIL (FLUSH)

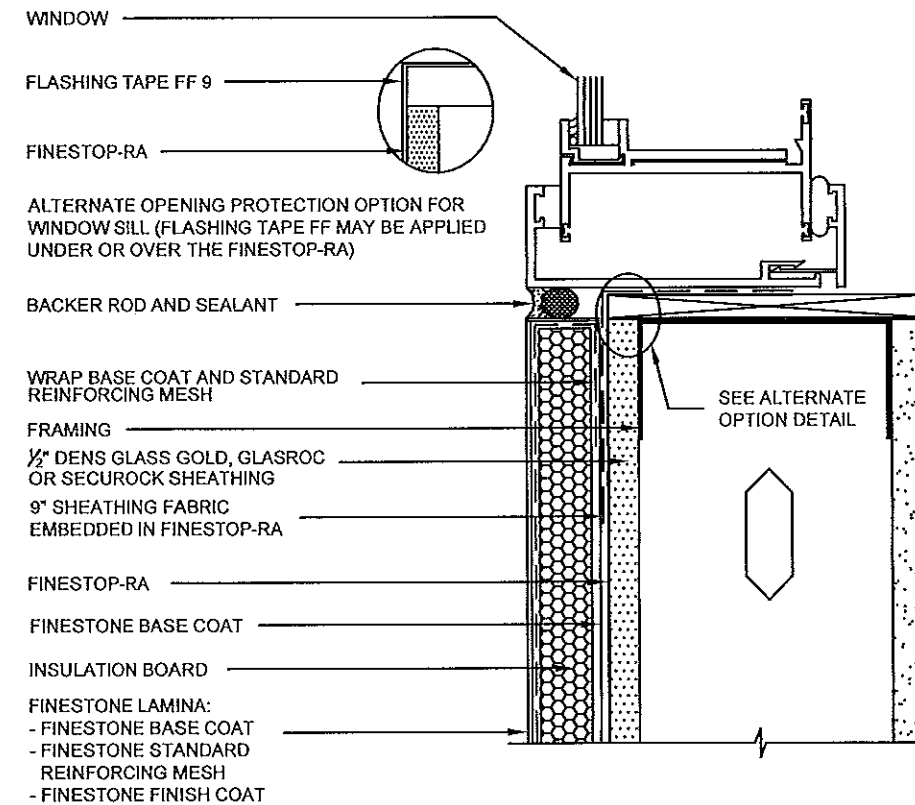

WINDOW SILL DETAIL (FLUSH)

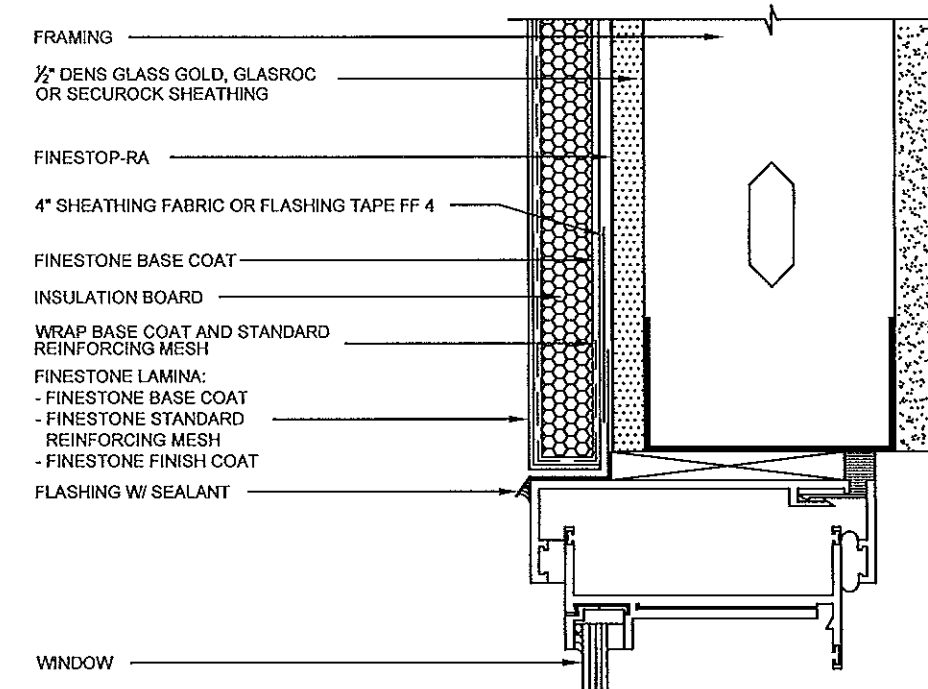

WINDOW HEAD (FLUSH)

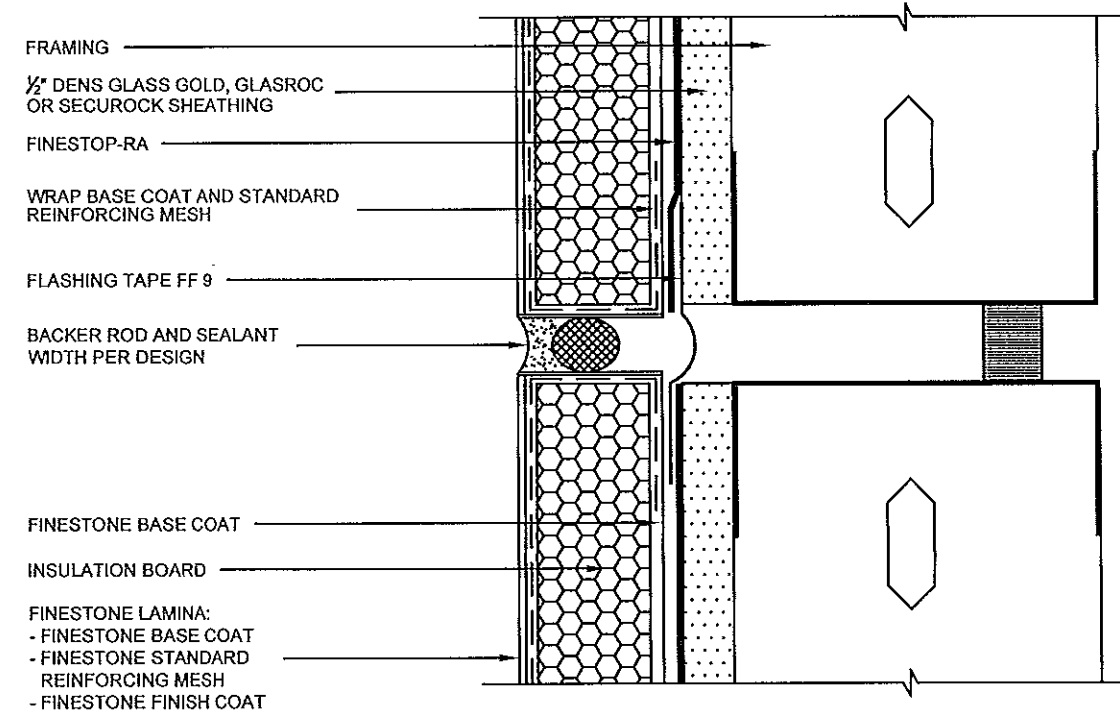

EXPANSION JOINT DETAIL

# FINESTONE

DATE: 12/10/13 Page 4 of 4

Details for Pebbletex-DCA Wall System with Finestop-RA over Dens Glass Gold, GlasRoc or Securock Sheathing and 18ga or 20ga Steel Frame (Small Missile)

DWG No. 004

REVISIONS	DATES
Added Securock	6/16/09

FLORIDA P.E.: William O. Bishop, P.E.  
REGISTRATION NO.: 63305

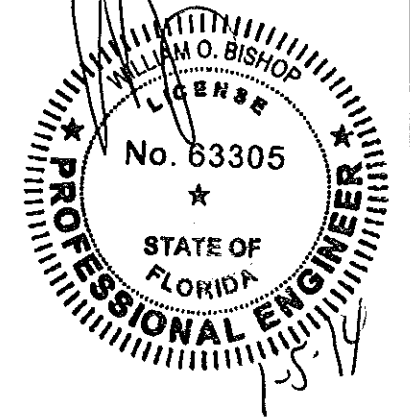

FOR OFFICE USE

PRODUCT RENEWED  
as complying with the Florida  
Building Code  
Acceptance No. 14-012114  
Expiration Date 04/29/2019

By *[Signature]*  
Miami Dade Product Control

BASF Corporation  
3550 St Johns Bluff Rd South  
Jacksonville, FL 32224  
800-221-9255

